

Secondary Infusion Set

DESCRIPTION

The Secondary Infusion Set includes a vented spike with drip chamber and a 15µm filter. The 115cm kink resistant standard tubing is made from medical grade PVC, and includes a male luer lock connector and roller regulator.

FEATURES & BENEFITS

- Vented perforator
- Male luer lock connector
- Rigid roller regulator for accurate flow
- Peel open pouch
- Single use only

PRODUCT DATA

- Tubing diameter 3.0mm
- Tubing length 115cm
- Priming volume: 13.0mL
- Drip chamber: 20 drops /mL
- Filter: 15µm
- Sterile EO
- ARTG Number: 304860
- The product is MRI and CT suitable
- DEHP NO = Not detected (Result less than the Method Detection Limit EN 14372)
- Not made with Natural Rubber Latex
- Material: PVC, PE, ABS, PA, MBS
- Shelf Life: 3 Years

ISO STANDARDS

- EN ISO 8536-4:2013 Infusion equipment for medical use- part 4: infusion set
- ISO 594/1; Conical Fittings with a 6% (Luer) Taper for Syringes, Needles and certain other Medical Equipment – Part 1: General Requirements
- ISO 594/2; Conical Fittings with a 6% (Luer) Taper for Syringes, Needles and certain other Medical Equipment – Part 2: Lock Fittings

PRODUCT DIAGRAM

ITEM	DESCRIPTION
1	Vented Perforator
2	Drip Chamber
3	Infusion Filter
4	Tubing
5	Regulator
6	Rotating Luer Lock
7	Cap

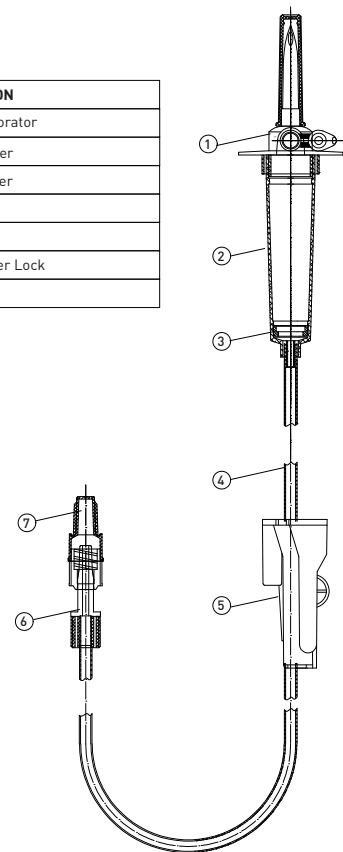

Secondary Infusion Set			STERILE
RE-ORDER	DESCRIPTION	LENGTH	CARTON/QTY
IV012000	Secondary Infusion Set	115cm	100